

BLINK SOLAR

Use battery storage



Overview

Why do we need battery storage systems?

Battery storage systems are revolutionizing the way we consume and manage energy. By enabling effective energy storage, these systems play a critical role in the transition to renewable energy sources. Incorporating battery storage systems benefits individual consumers and contributes to the overall stability and resilience of our energy grids.

What is a battery energy storage system?

2.1. Battery energy storage systems (BESS) Electrochemical methods, primarily using batteries and capacitors, can store electrical energy. Batteries are considered to be well-established energy storage technologies that include notable characteristics such as high energy densities and elevated voltages .

What is home battery storage systems?

Home Battery Storage Systems What is Battery Storage?

Battery storage refers to systems that store energy for later use. These systems can be standalone or integrated with renewable energy sources, allowing users to harness energy during peak production times and utilize it when demand increases.

Why should you take a solar battery storage course?

These courses on solar battery storage systems will help you enhance energy efficiency and sustainability, paving the way for a greener future. Battery storage systems are revolutionizing the way we consume and manage energy. By enabling effective energy storage, these systems play a critical role in the transition to renewable energy sources.

Use battery storage



The Battery Storage Delusion: Utility-Scale ...

Download Issue Brief The Issue Utility-scale lithium-ion battery energy storage systems (BESS), together with wind and solar power, are ...

Your guide to home batteries in 2025

Are you considering a home battery? Learn about investing in battery storage for your energy needs.



Energy Storage Batteries

As the adoption of renewable energy storage continues to grow rapidly, the demand for efficient and reliable energy storage ...

What is Battery Storage?

Grid-scale batteries Grid-scale battery storage is a technology that enables utilities and power system operators to store large amounts ...



Battery storage

Batteries are an energy storage technology that use chemicals to absorb & release energy on demand. Lithium-ion is the most common battery ...



Battery Energy Storage Systems Explained: What They Are ...

A battery energy storage system stores energy in batteries for later use, balancing supply and demand while supporting renewable energy integration.



What is battery storage? , National Grid

Battery storage, or battery energy storage systems (BESS), are devices that

enable energy from renewables, like solar and wind, to be ...



Battery Energy Storage Systems (BESS): A ...

Explore Battery Energy Storage Systems (BESS), their types, benefits, challenges, and applications in renewable energy, grid support, ...



Stationary, Second Use Battery Energy ...

Battery energy storage systems have been investigated as storage solutions due to their responsiveness, efficiency, and scalability. ...

Energy Storage Batteries

As the adoption of renewable energy storage continues to grow rapidly, the demand for efficient and reliable energy

storage solutions has also surged.
Energy storage ...



Energy Storage Systems: Batteries

Batteries, as a form of energy storage, offer the ability to store electrical energy for later use, thereby balancing supply and demand, enhancing ...

The Ultimate Guide to Battery Energy Storage Systems ...

Maximize your energy potential with advanced battery energy storage systems. Elevate operational efficiency, reduce expenses, and amplify savings. Streamline your energy ...



Understanding Battery Storage for Renewable Energy Systems

Discover the various battery storage systems, technologies, and applications



to enhance energy efficiency and support renewable energy integration. As the world ...

A review of battery energy storage systems and advanced battery

This article provides an overview of the many electrochemical energy storage systems now in use, such as lithium-ion batteries, lead acid batteries, nickel-cadmium ...

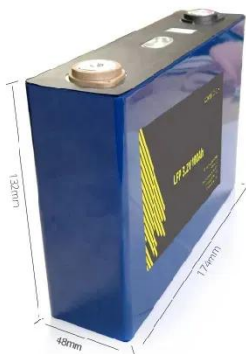

Battery Storage Paves Way for a Renewable ...

Battery storage systems are emerging as one of the key solutions to effectively integrate high shares of solar and wind renewables ...

Battery Energy Storage: How it works, and why it's important

Learn how battery energy storage systems work, their key components,

and why they are vital for reliable, cost-efficient, and sustainable power.

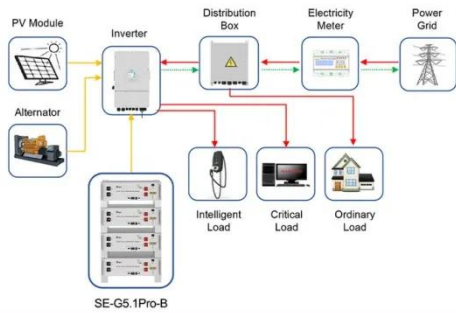

Application scenarios of energy storage battery products

What is battery storage? , National Grid

Battery storage, or battery energy storage systems (BESS), are devices that enable energy from renewables, like solar and wind, to be stored and then released when the power ...

Stationary Energy Storage , Battery Council International

Stationary energy storage is critical to supporting a strong energy future - delivering the reliability, resilience, and sustainability our nation depends on. To meet diverse ...



Battery Energy Storage: How it works, and ...

Learn how battery energy storage systems work, their key components,

and why they are vital for reliable, cost-efficient, and ...



The Ultimate Guide to Battery Energy Storage ...

Maximize your energy potential with advanced battery energy storage systems. Elevate operational efficiency, reduce expenses, and ...



What is Battery Storage?

Grid-scale batteries Grid-scale battery storage is a technology that enables utilities and power system operators to store large amounts of energy for later use. They are ...



Energy storage

Technology costs for battery storage continue to drop quickly, largely owing to the rapid scale-up of battery

manufacturing for electric ...

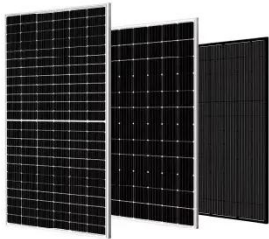

Battery technologies for grid-scale energy storage

Energy-storage technologies are needed to support electrical grids as the penetration of renewables increases. This Review discusses the application and development ...

The Battery Storage Delusion: Utility-Scale Batteries Are No ...

Download Issue Brief The Issue Utility-scale lithium-ion battery energy storage systems (BESS), together with wind and solar power, are increasingly promoted as the ...



Wind and Solar Energy Storage , Battery ...

Solar and wind facilities use the energy stored in lead batteries to reduce power

fluctuations and increase reliability to deliver on ...



Contact Us

For catalog requests, pricing, or partnerships, please contact:

BLINK SOLAR

Phone: +48-22-555-9876

Email: info@blinkartdesign.pl

Website: <https://www.blinkartdesign.pl>

Scan QR code to visit our website:

