

BLINK SOLAR

Solar container outdoor power for fire protection



Overview

What is a 20ft container energy storage system?

It also includes automatic fire detection and alarm systems, ensuring safe and efficient energy management. The 20FT Container 250kW 860kWh Battery Energy Storage System is a highly integrated and powerful solution for efficient energy storage and management.

How do you protect a solar system from a fire?

On the surface, the process seems simple, however, there are many steps required to ensure safety. Firefighters arrive at the scene of a fire, and then identify the solar system on the structure, shut it down, watch for hazards as they extinguish the flames, and make sure the scene is safe when they leave.

What is a 20ft container 250kW 860kwh battery energy storage system?

Equipped with automatic fire detection and alarm systems, the 20FT Container 250kW 860kWh Battery Energy Storage System is the ultimate choice for secure, scalable, and efficient energy storage applications. Email us with any questions or inquiries or use our contact data.

Can firefighters respond to solar energy fires?

As solar energy systems become more common, firefighters need to be equipped with the knowledge to safely respond to fires involving PV-equipped structures. SETO awardee, IREC, developed free, self-paced, interactive online training and live workshops designed specifically for firefighters.

Solar container outdoor power for fire protection



A Guide to Fire Safety with Solar Systems

The solar office funded the Solar Training and Education for Professionals program, which provides tools to firefighters and fire code ...

Outdoor Power Supply Smart Solar Container Battery Energy ...

Its microgrid solutions integrate distributed energy resources, such as solar PV, wind, and energy storage, to create resilient and self-sufficient power networks ideal for ...



Energy Storage Container Fire Protection ...

The fire protection system for energy storage containers plays an indispensable role in ensuring the safety of renewable energy. Fully ...

Container Power House: Portable Power Core for Off-Grid ...

Learn about the benefits of solar container homes and how they provide reliable off-grid energy through modular energy storage, hybrid energy compatibility and rapid ...

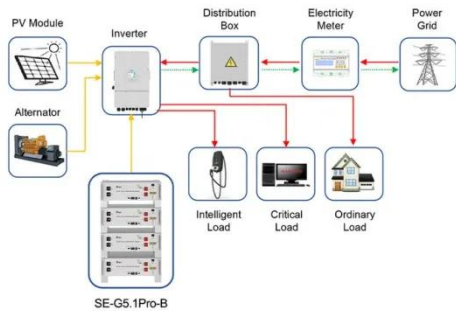

Application scenarios of energy storage battery products

Energy Storage Container Fire Protection System: A Key ...

The fire protection system for energy storage containers plays an indispensable role in ensuring the safety of renewable energy. Fully understanding and addressing the ...

Outdoor ESS Container 500kW 1MWh Commercial All-in-One Grid Solar

Battery Protection: Built-in Smart BMS
 Battery Type: Lifepo4/lithium Battery ESS container: 10/20/40ft Air Conditioning/fire Extinguishing Type: 20GP/40GP Container Solutions ...



FIRE PROTECTION ACCEPTANCE STANDARDS FOR OUTDOOR ...

The energy storage outdoor cabinet adopts an integrated design solution

This 100KW 215KWH C&I BESS cabinet adopts an integrated design, integrating battery cells, BMS, PCS, fire ...



A Guide to Fire Safety with Solar Systems

The solar office funded the Solar Training and Education for Professionals program, which provides tools to firefighters and fire code officials.



Energy Storage Safety: Fire Protection ...

3 re extinguishing agent delivery pipeline: When the energy storage container fire protection system uses pipe network type ...



Can I run power to a shipping container? Off ...

Off-Grid Solar Container Power: steps from load assessment to GFCIs, using

SolarContainer or LZY-MSC1 units.



Essentials on Containerized BESS Fire Safety System-ATESS

Fire protection systems for energy storage containers are critical to ensuring the safe operation of energy storage power stations. As batteries with higher energy densities ...

Can I run power to a shipping container? Off-Grid Solar ...

Off-Grid Solar Container Power: steps from load assessment to GFCIs, using SolarContainer or LZY-MSC1 units.



Energy Storage Safety: Fire Protection Systems Explained

3 re extinguishing agent delivery pipeline: When the energy storage

container fire protection system uses pipe network type heptafluoropropane, special gas pipelines will be ...



20FT Container 250KW 803KWH Battery Energy Storage ...

The Bluesun 20-foot BESS Container is a powerful energy storage solution featuring battery status monitoring, event logging, dynamic balancing, and advanced protection ...



Container Power House: Portable Power Core ...

Learn about the benefits of solar container homes and how they provide reliable off-grid energy through modular energy storage, ...

Contact Us

For catalog requests, pricing, or partnerships, please contact:

BLINK SOLAR

Phone: +48-22-555-9876

Email: info@blinkartdesign.pl

Website: <https://www.blinkartdesign.pl>

Scan QR code to visit our website:

