

# BLINK SOLAR

## Solar container battery container voltage



## Overview

---

What is a container battery energy storage system?

Understanding its Role in Modern Energy Solutions A Container Battery Energy Storage System (BESS) refers to a modular, scalable energy storage solution that houses batteries, power electronics, and control systems within a standardized shipping container.

How to implement a containerized battery energy storage system?

The first step in implementing a containerized battery energy storage system is selecting a suitable location. Ideal sites should be close to energy consumption points or renewable energy generation sources (like solar farms or wind turbines).

What is a Solax containerized battery storage system?

SolaX containerized battery storage system delivers safe, efficient, and flexible energy storage solutions, optimized for large-scale power storage projects. As the world increasingly transitions to renewable energy, the need for effective energy storage solutions has never been more pressing.

What is containerized battery storage?

Because containerized battery storage units can be mass-produced and are modular in design, they are often more cost-effective than traditional energy storage solutions. The initial capital investment is lower, and the system can be expanded over time without requiring significant upgrades to infrastructure.

## Solar container battery container voltage

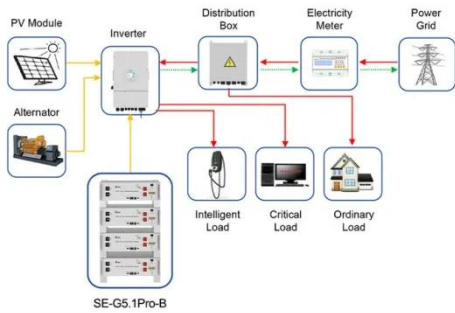

Application scenarios of energy storage battery products

### 1MWh / 2MWh / 3.72MWh / 5MWh Containerized Ener

GSL Energy's 1MWh-5MWh Battery Energy Storage System (BESS) in a 20FT container is an advanced energy storage solution for commercial and industrial use. This scalable and reliable ...

### MOBIPOWER Battery Energy Storage Systems , Off-Grid Solar Container

MOBIPOWER hybrid clean power containers combine battery energy storage systems with off-grid solar containers for remote industrial sites in Canada & USA.



### Container Energy Storage Voltage: The Backbone of Modern ...

Why Container Energy Storage Voltage Is the Talk of the Town Ever wondered how renewable energy projects keep the lights on when the sun isn't shining or the wind isn't blowing? Enter ...

## Sunpal Lithium Battery Solar Powered Container Bess 1Mwh

...

Battery Cell The battery core adopts lithium iron phosphate battery-LFP 48173170E, the capacity is 120Ah, the nominal voltage is 3.2V, the working voltage range is 2.5~3.65V, the ...



## Mobile Solar Container Power Generation Efficiency: Real ...

A mobile solar container is simply a portable, self-contained solar power system built inside a standard shipping container. These types of containers involve photovoltaic (PV) ...

## How Do Solar Power Containers Work and What Are They?

One such innovation gaining rapid adoption is the solar power container. Solar power containers combine solar photovoltaic (PV) systems, battery storage, inverters, and ...



**containerized battery storage ,  
SUNTON POWER**



The shipping container solar system consists of a battery system and an energy conversion system. Lithium-ion battery energy storage systems contain advanced lithium iron ...

---

## Specification of 5MWh Battery Container System

customized configurations, ease of maintenance, and future expansion capacity. The battery Pack consists of 104 single cells, the specification is 1P104S, the power is ...



---

## Sunway 1Mw Battery Container Energy Storage System



ESS Container Battery Sunway Ess battery energy storage system (BESS) containers are based on a modular design. They can be configured to match the required power and capacity ...

---

## How a Containerized Battery Energy Storage System Can ...

A Container Battery Energy Storage System (BESS) refers to a modular,

scalable energy storage solution that houses batteries, power electronics, and control systems within a ...



---

## Contact Us

---

For catalog requests, pricing, or partnerships, please contact:

### **BLINK SOLAR**

Phone: +48-22-555-9876

Email: [info@blinkartdesign.pl](mailto:info@blinkartdesign.pl)

Website: <https://www.blinkartdesign.pl>

*Scan QR code to visit our website:*

