

**BLINK SOLAR**

# **After-sales service for 500kW photovoltaic container**



## Overview

---

How to choose a 500 kW / 1075 kWh containerized energy storage system?

When choosing a 500 kW / 1075 kWh containerized energy storage system, you need to consider your application scenarios, equipment performance, system security, scalability, vendor reputation and many other factors. Ensure that the system you choose can meet your long-term needs and provide adequate support and service guarantees.

What is zeconex factory commercial wholesale battery power storage system?

Zeconex factory commercial wholesale battery power storage solution - the containerized energy storage system integrates 500KW/1075KWH battery energy storage.

What is a containerized energy storage system?

This containerized energy storage system not only integrates the most advanced technology, but also becomes the global leader in the field of energy storage with its excellent performance, efficient energy management and unparalleled reliability.

## After-sales service for 500kW photovoltaic container

---



### Solar Wind and Generator Systems 200kw 300kw 500kw Power Container

Solar Wind and Generator Systems  
200kw 300kw 500kw Power Container,  
Find Details and Price about PV Module  
Price Electrical Energy Storage from  
Solar Wind and ...

### 100kw 250kw 300kw 500kw Grid- Connected ...

100kw 250kw 300kw 500kw Grid-  
Connected off Grid Solar Energy Power  
System LiFePO4 Lithium Battery Bess  
Industrial Commercial Energy ...

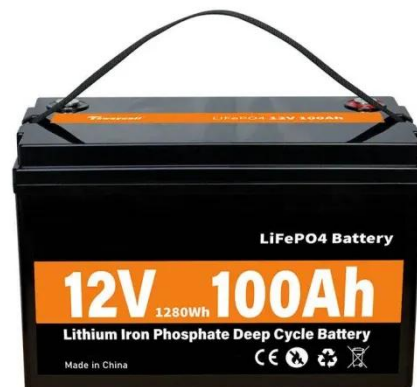

### Industrial and Commercial Use 500kw Storage Solar System ...

After-sales Service: Support Warranty:  
25years Condition: New Certification: CE  
Application: Industrial, Commercial  
Specification: Normal, solar panel,  
inverter

**Containerized Bess 500kwh 1MW  
20FT 40FT ...**

(TANFON 2.5MW solar energy storage project in Chad) Containerized Bess 500kwh 1MW 20FT 40FT Container Solar Storage ...



**Containerized Bess 500kwh 1MW  
20FT 40FT Container Solar ...**

Containerized Bess 500kwh 1MW 20FT 40FT Container Solar Storage System This scheme is applicable to the distribution system composed of photovoltaic, energy ...

**Container Energy Storage System  
on Grid 500kw Solar ...**

After-sales Service: Yes Warranty: 10years Condition: New Certification: ISO, CB, CE Application: Home, Industrial, Commercial Specification: Normal, 500KW On Grid

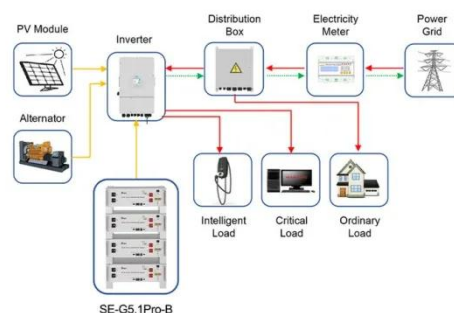

Application scenarios of energy storage battery products

**Container Energy Storage System  
on Grid ...**

After-sales Service: Yes Warranty: 10years Condition: New Certification:

ISO, CB, CE Application: Home, Industrial, Commercial ...



---

### **High Voltage Solar Container 500kw Energy Generation with ...**

After-sales Service: Support Warranty: 25years Condition: New Certification: CE Application: Industrial, Commercial Specification: Normal, solar panel, inverter



---

### **500kw to 2MW Advanced LiFePO4 Container Battery Pack ...**

The company adheres to the customer as the center, the design of practical and convenient system solutions, the production of stable and reliable good products, to provide ...

---

### **Sail Solar 500kw Lithium Ion Hybrid Solar Container Battery ...**

SAIL SOLAR is a professional photovoltaic products manufacturer, we

specializes in research, production and sales of solar photovoltaic products and solar energy system. Our ...



### **Bluesun container solution 500kw 250kw 2.7MWh off grid ...**

Bluesun Solar ---is one of the solar power solution leading companies in China. Specializing in research and development of solar panel, lithium battery and BMS. Bluesun product has ...

### **C& I ESS 500KW 1000KW 1MWh 2MWh Solar Energy Storage Container**

VoltaNest has won the unanimous recognition of consumers with satisfactory quality and perfect after-sales service. We can provide customized services and overseas installation services ...



### **One-Stop Solution For Solar & BESS. Powered By 20 Years Of ...**

500KW-10MW Utility-Scale PV & BESS A



500KW-10MW utility-scale solar plant is a strategic investment in energy independence and cost stability. It turns your underutilized spaces--from ...

---

### Sunrange 500kw 1mwh 2mwh 20FT Energy Storage Container ...

Together with our products advantage, we can design professional PV system solutions, produce reliable system products and provide satisfying after sale service.



---

### Energy Storage System 500kw Battery ...

Together with our products advantage, we can design professional PV system solutions, produce reliable system products and ...

---

### 300kw 500kw 800kw Sunway Energy Storage ...

300kw 500kw 800kw Sunway Energy Storage Container 1MW Energy Storage

System, Find Details and Price about Solar Panel ...



### **Containerized Energy Storage System , 500KW / 1075KWH**

What are the advantages of the 500KW/1075KWH integrated energy storage system? The 500KW/1075KWH integrated energy storage system provided by Zeconex ...

### **Commercial 500kw 1000kwh Inverter Container Battery ...**

Commercial 500kw 1000kwh Inverter Container Battery Energy Storage System, Find Details and Price about 50kw Inverter Cabinet Battery Energy Storage System from ...



### **500kw 1mwh kVA Battery Storage Container 1MW Solar ...**

Together with our products advantage, we can design professional PV system

solutions, produce reliable system products and provide satisfying after sale service. With ...



**Containerized Bess 500kwh 1MW 20FT 40FT ...**

Containerized Bess 500kwh 1MW 20FT 40FT Container Solar Storage System This scheme is applicable to the distribution system ...



**100kw 150kw 250kw 500kw Container Photovoltaic Power ...**

We have comprehensive pre-sales and after-sales services. When we receive an order, we have standard procedure to provide client with a production and processing ...

**Megarevo - Industry-Leading Hybrid Inverter ...**

Partnering with over 200 renowned enterprises worldwide, Megarevo

delivers more than just energy storage or hybrid inverters. We are also committed ...



### **Namkoo 500kw 1MW PV Power Container ...**

Basic Info. After-sales Service Design, Supply and Installation Warranty 5years, 20 Years Condition New Certification CE, TUV ...

### **Energy Storage System 500kw Battery Storage Solar Proect Container**

Together with our products advantage, we can design professional PV system solutions, produce reliable system products and provide satisfying after sale service. With ...



### **Sunrange 500kw 1mwh 2mwh 20FT Energy ...**

Together with our products advantage, we can design professional PV system

solutions, produce reliable system products and ...



---

## Containerized Energy Storage System

What are the advantages of the 500KW/1075KWH integrated ...



---

## Contact Us

For catalog requests, pricing, or partnerships, please contact:

### **BLINK SOLAR**

Phone: +48-22-555-9876

Email: [info@blinkartdesign.pl](mailto:info@blinkartdesign.pl)

Website: <https://www.blinkartdesign.pl>

*Scan QR code to visit our website:*

