

BLINK SOLAR

100 degree battery cabinet price

ESS



Overview

How many battery cells are in a battery cabinet?

Each battery cabinet is with 240 battery cells in series with contactor, detective unit, sampling line, battery management systems, fuse, etc. BESS employs a sophisticated, multilevel battery management system (BMS) for system monitoring and control. Each battery management system including:

Where are battery cabinet suppliers?

There are 20,147 battery cabinet suppliers, mainly located in Asia. The top supplying countries or regions are China, Argentina, and Hong Kong S.A.R., which supply 99%, 1%, and 1% of battery cabinet respectively. Battery cabinet products are most popular in North America, Western Europe, and Southeast Asia.

How many temperature detectors does a battery module have?

internally to prevent short circuit to ensure the electrical safety of the battery module. Each battery module has 16 temperature detectors. Power Conditioning System (SP100ELL) is a bi-directional conversion system to convert power between static energy storage and grid or load with add-on features of power quality management.

100 degree battery cabinet price



IP65 Battery Cabinet

A UPS battery cabinet is the perfect solution for keeping your batteries secure and dry. The battery storage cabinet protects from moisture and ensures that your batteries remain ...

100kWh Solar Battery Storage Cabinet 280Ah LiFePO4 Battery

...

GSL-100 (DC50) (215kWh) (EV120)
 100kWh Solar Battery Storage Cabinet
 280Ah LiFePO4 Battery Air-cooling
 Photovoltaic Charging Energy Storage
 Cabinet is an efficient and ...

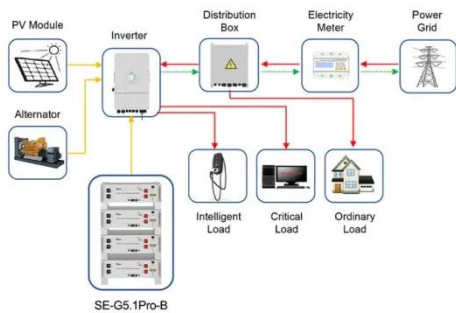
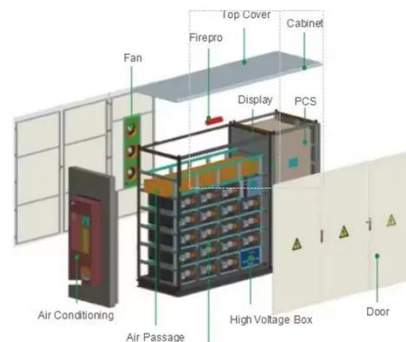

Application scenarios of energy storage battery products

Commercial 100kwh LiFePO4 Battery Cabinet for Energy ...

Commercial 100kwh LiFePO4 Battery Cabinet for Energy Storage, Find Details and Price about Battery 5kw Solar System 48V Solar Battery System from Commercial ...

All-In-One Hybrid Battery Cabinet 100kwh 200kwh Battery ...

Feature highlights: The All-In-One Hybrid Battery Cabinet offers 100kWh and 200kWh capacities, designed for commercial solar energy storage with an IP55 protection class and air-cooling ...

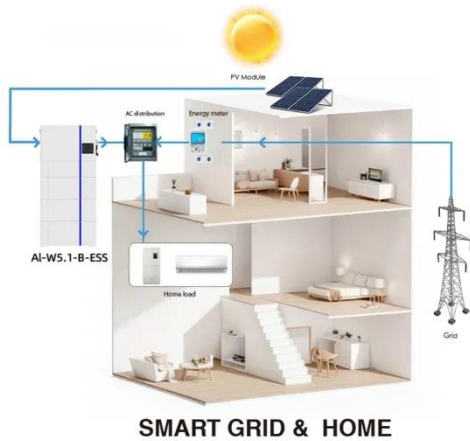

100kW 215kWh All-in-One Battery Storage Cabinet

All-in-One Battery Storage System The iCON 100kW 215kWh Battery Storage System is a fully integrated, on or off grid battery solution that has liquid cooled battery storage (215kWh), ...

Hitek Industrial Lithium Battery Cabinet 100kw 200kw ...

Hitek Industrial Lithium Battery Cabinet 100kw 200kw 215kwh 232kwh Liquid Cooling System Power Supply Unit Battery Container Cabinet System, Find Details and Price ...



Sunark High Degree of Integration Solar Battery Cabinet ...



Sunark High Degree of Integration Solar Battery Cabinet 100kwh 150kwh 200kwh Container, Find Details and Price about Prefabricated Box Special Box from Sunark High ...

All in One Battery Energy Storage Cabinet 100kw 215kw

...

All in One Battery Energy Storage Cabinet 100kw 215kw Solar Energy Batteries System Installation, Find Details and Price about Battery Storage System Battery Storage ...

INTEGRATED DESIGN
EASY TO TRANSPORT AND INSTALL,
FLEXIBLE DEPLOYMENT



Contact Us

For catalog requests, pricing, or partnerships, please contact:

BLINK SOLAR

Phone: +48-22-555-9876

Email: info@blinkartdesign.pl

Website: <https://www.blinkartdesign.pl>

Scan QR code to visit our website:

